

Dust Cover Removal Tool for Shimano 35010423001804  
Dust Cover Removal Tool for DUB 35010422001804

### Before installation

Use only the tools recommended in this manual.  
Do not modify the product in any way that could endanger the rider or others.  
Any modification to the product will void the warranty.  
If you have any questions, please contact your authorized Bikone dealer or workshop, or download the manual from: <https://www.bikone.com/downloads/>

### During use

This tool is made with gentle materials to protect the bottom bracket from any damage; make sure not to force the product to avoid any damage.  
Always use this product in a clean area, making sure that dust and moisture don't get inside.  
30 mm cranks do not require this product for maintenance.

### 01 What is it for

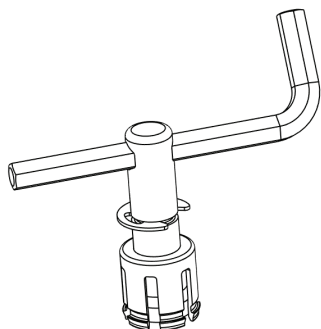

This tool is specifically designed to remove the "dust cover" from the bottom bracket without needing to disassemble it and without damaging the part. It allows quick bearing maintenance. Use an Allen key or a rod under 8 mm in diameter as a handle for removal.

### 02 Extractor positions

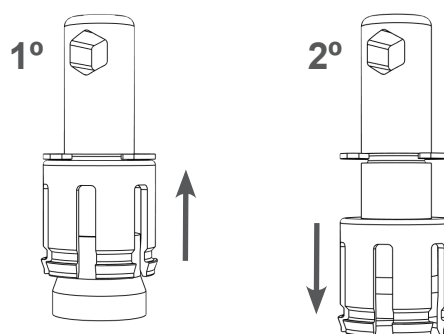

It has two positions:  
1st: Insertion; allows the prongs to flex when passing through the "dust cover".  
2nd: Removal; the prongs lock to extract the "dust cover".

### 03 Insert "Dust Cover Removal tool"

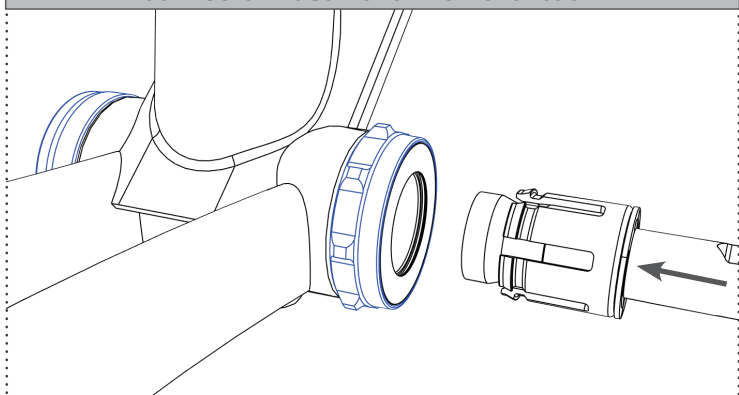

Apply force inward into the bottom bracket until you hear a click. At that moment, the prongs will be in position. Holding the moving part, pull the central body slightly backward to lock the prongs.

### 04 Fit the handle

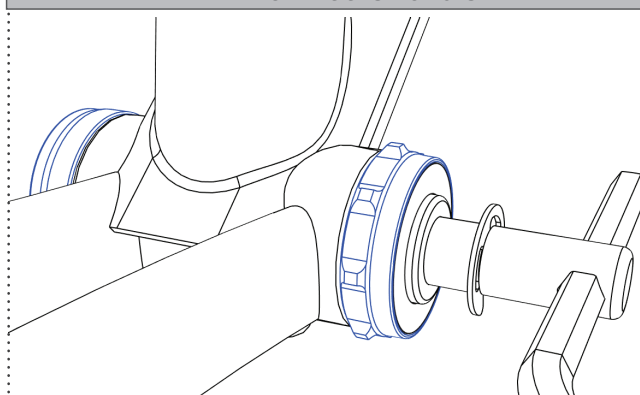

Once in position, fit a handle to perform the removal.

### 05 Pull outward

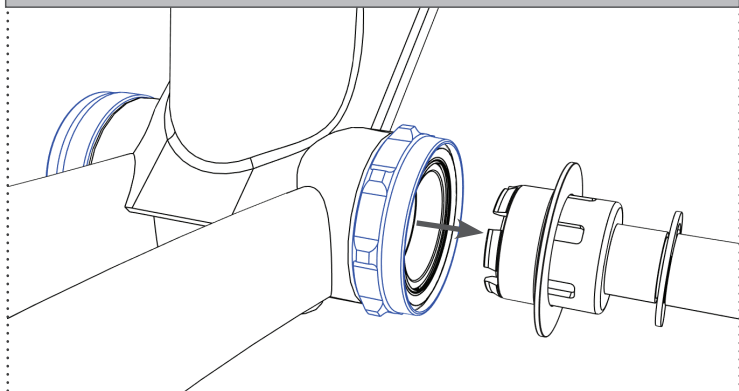

Pull outward while trying to keep a straight direction to avoid damaging the tool, the "dust cover", or the bearing. This effort must be firm and without impacts.

### 06 Remove the "dust cover"

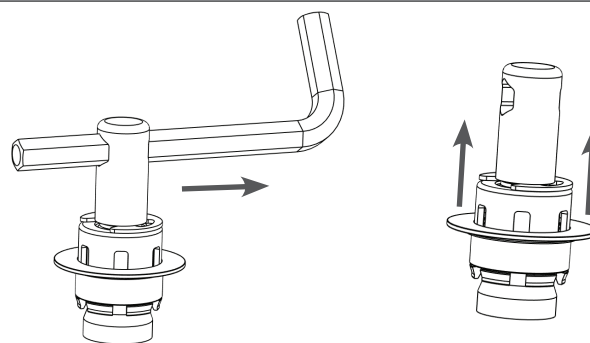

Once the "dust cover" has been extracted, you must remove it from the tool. To do so, remove the handle (Allen key, screwdriver, or rod) and slide the "dust cover" in the direction indicated by the arrow.