

Assembly Instructions for DCTech - Threaded

BSA / T45 / T47

Before Installing

Use the tools recommended in this manual
Do not alter the product in any way that may cause risk to the rider or others.
Any modification to the product will void the warranty.
In case of doubt consult your authorised bikone workshop or download at: <https://www.bikone.com/downloads/>

During use

Check that there is no lateral movement in the crankset and turn smoothly,
Make sure that the cranks are correctly adjusted and tightened to the torque specified by the manufacturer.
Never clean the bottom bracket with direct water pressure or brake cleaning fluid.
A soft brush or wet cloth and soap is recommended.

Installation

Attention! Check your frame

Some frames may have screws in the middle and need to be replaced by shorter ones or steps blocking the interior installation.

Dimensional info at:
<https://www.bikone.com/downloads/>

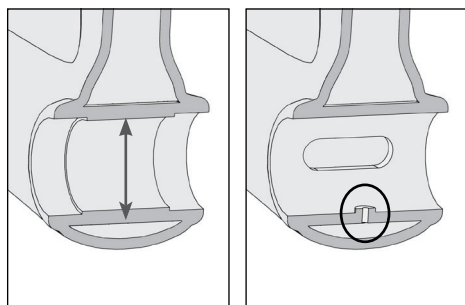

Assembly tool:

BSA for Shimano. Parktool BBT-69.3, Shimano TL-FC32 or similar: $\varnothing 44$ mm outside and $\varnothing 42.7$ mm inside. 16 notch.

BSA for DUB / BB30: BSA tool 24 or 12 pins : $\varnothing 45,5$ MM outside and $\varnothing 44$ mm inside. 24 notch.

T47 / T45: Parktool BBT-47-16 or similar: $\varnothing 52$ mm outside and $\varnothing 48.2$ mm inside. 16 notch.

Recommended greases: FinishLine Premium Grease / Park Tool PPL-1 Polyube 1000 / Muc-Off Bio Grease / Others

Do not use carbon paste or brake cleaner under any circumstances.

01 - Greasing of surfaces

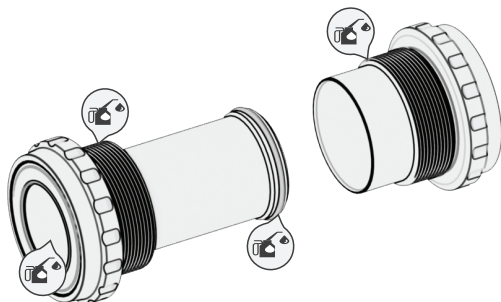

Apply grease to the indicated contact surfaces.

02 - Cup threading

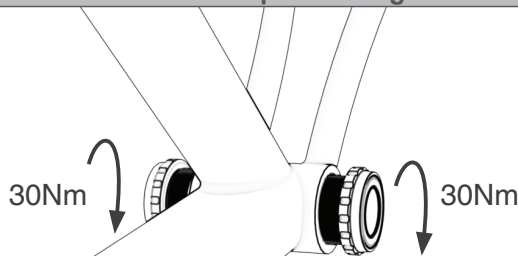

Tight both cups by hand or with the help of the 'assembly tool', preferably at the same time so that the DCTech system aligns the BB correctly.
Once both cups are tightened to the frame, tighten to the specified torque.

03 - Install spacers or O-rings

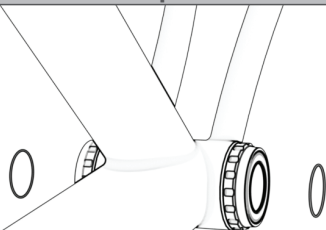

Install spacers or O-rings depending on model,
See at: <https://www.bikone.com/downloads/>

04 - Install connecting rods

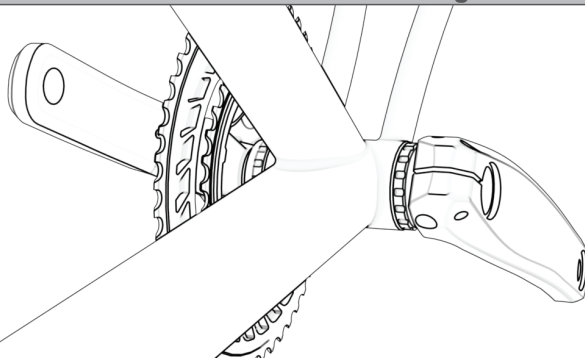

Grease and install crankset following the manufacturer's assembly steps.

Disassembly Tool

BSA: Parktool BBT-69.3 or Shimano TL-FC32 or similar: $\varnothing 44$ mm outside and $\varnothing 42.7$ mm inside 16 notch.
 T47: Parktool BBT-47-16 or similar: $\varnothing 52$ mm outside and $\varnothing 48.2$ mm inside 16 notch.

01 - Remove the crankset

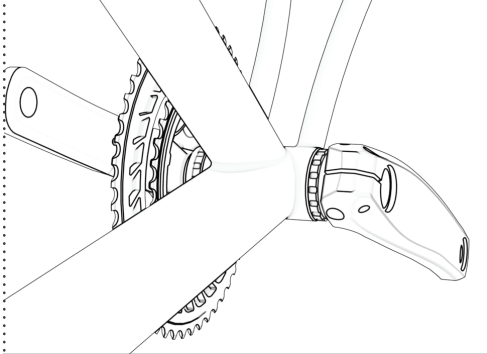

Remove the crankset

02 - Release cups

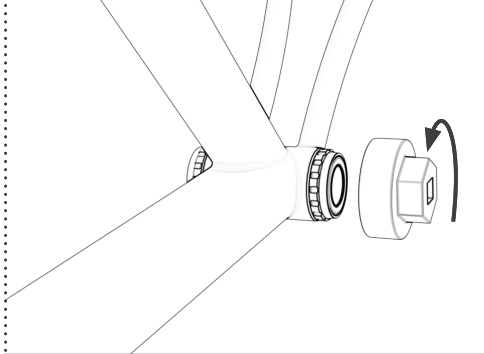

With the help of your tool, untighten by applying the required torque in the direction of rotation indicated on the cup.

03 - Unscrew the cups

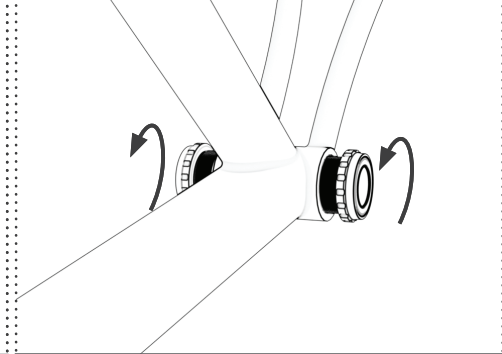

Loosen in the opposite direction of rotation indicated on the cup.

Warranty

All Bikone bottom brackets are warranted against product defects for 3 years from the date of purchase.
 This warranty applies to the original owner of purchase and is not transferable to future owners.
 The warranty does not cover damage caused by use on wear parts.
 The warranty does not cover damage caused by improper installation.
 Please refer to our website for more information or visit an authorised dealer.